



Doc. Version	0.1
Total Page	23
Date	2007/03/15

Product Specification

3.5" COLOR TFT-LCD MODULE

MODEL NAME: A035QN01 V8

(Green Product, RoHS compliance)

< > Preliminary Specification

< > Final Specification

Note: The content of this specification is subject to change.

© 2006 AU Optronics
All Rights Reserved,
Do Not Copy.



Record of Revision

Version	Revise Date	Page	Content
0	2006/12/22		First draft.
0.1	2007/03/15	9	Revise electrical characteristics
		13-17	Revise command register R3
		19	Add note2

Contents:

<u>A.</u>	<u>General Description</u>	<u>3</u>
<u>B.</u>	<u>Features</u>	<u>3</u>
<u>C.</u>	<u>Physical Specifications</u>	<u>4</u>
<u>D.</u>	<u>Outline Dimension</u>	<u>5</u>
<u>E.</u>	<u>Electrical Specifications</u>	<u>6</u>
	1. Pin Assignment.....	6
	2. Absolute Maximum Ratings	8
	3. Electrical Characteristics	9
	a. TFT- LCD Panel (GND=0V)	9
	b. Backlight Driving Conditions	10
	4. AC Timing.....	11
	a. Timing Condition.....	11
	b. Timing Diagram	12
	5. Command register map	13
	a. Command timing : Serial Peripheral Interface	13
	b. Serial setting map.....	13
	c. Description of serial control data	錯誤! 尚未定義書籤。
	c-1. R0	錯誤! 尚未定義書籤。
	c-2. R1	錯誤! 尚未定義書籤。
	c-3. R2	錯誤! 尚未定義書籤。
	c-4. R3	錯誤! 尚未定義書籤。
<u>F.</u>	<u>Optical specifications (Note 1, 2)</u>	<u>17</u>
<u>G.</u>	<u>Reliability Test Items</u>	<u>19</u>
<u>H.</u>	<u>Packing Form</u>	<u>20</u>
<u>I.</u>	<u>Application Note</u>	<u>21</u>
	1. Power on/off sequence	21
	2. Application Notes – Vcom driving circuit	22

A. General Description

A035QN01 V8 is an amorphous transmissive type Thin Film Transistor Liquid crystal Display (TFT-LCD). This model is composed of a TFT-LCD, drive and gate IC's, an FPC (flexible printed circuit) and a backlight unit.

B. Features

- QVGA resolution in RGB stripe dot arrangement
- High brightness
- 3-wire register setting
- Interfaces: parallel RGB 24-bit
- 2-in-1 FPC for LCD signals and backlight LED power
- Wide viewing angle
- Green design

C. Physical Specifications

NO.	Item	Unit	Specification	Remark
1	Display Resolution	dot	320 RGB (H)×240(V)	
2	Active Area	mm	70.08(H)×52.56(V)	
3	Screen Size	inch	3.5(Diagonal)	
4	Dot Pitch	mm	0.073(H)×0.219(V)	
5	Color Configuration	--	R. G. B. Stripe	Note 1
6	Color Depth	--	16.7M Colors	Note 2
7	Overall Dimension	mm	76.9(H) × 63.9(V) × 3.15(T)	Note 3
8	Weight	g	33.2	
9	Panel surface treatment	--	Hard coating 3H	
10	Display Mode	--	Normally White	

Note 1: Below figure shows dot stripe arrangement.

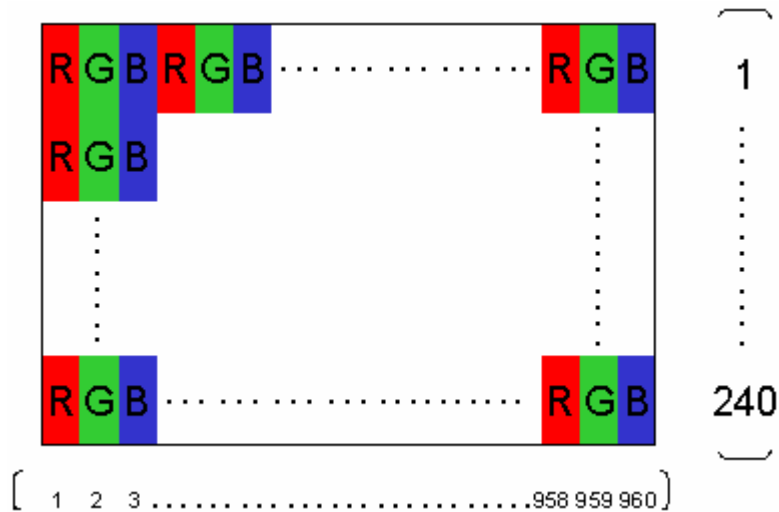

Note 2: The full color display depends on 8-bit data signal (pin12~35).

Note 3: Not include FPC. Refer to the next page for further information.

D. Outline Dimension

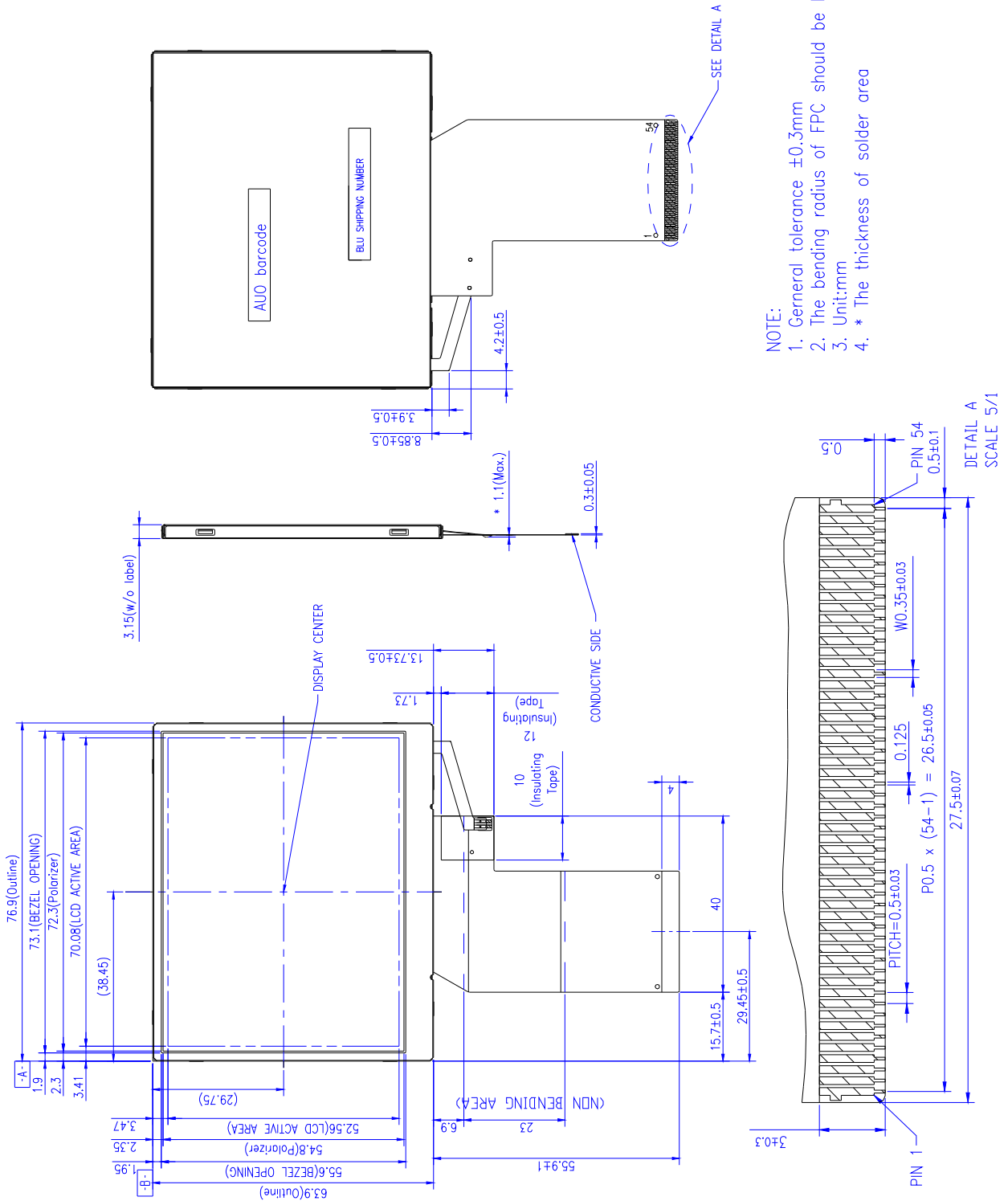

E. Electrical Specifications

1. Pin Assignment

No.	Pin Name	I/O	Description	Remarks
1	LED_Cathode	I	Backlight LED Cathode	
2	LED_Cathode	I	Backlight LED Cathode	
3	LED_Anode	I	Backlight LED Anode	
4	LED_Anode	I	Backlight LED Anode	
5	NC	-	Not Connected	
6	NC	-	Not Connected	
7	POL	O	The Signal to Generate VCOM	VDD / GND
8	RESET	-	Reset	
9	SPENA	I	SPI Interface Data Enable Signal	
10	SPCLK	I	SPI Interface Clock	
11	SPDAT	I	SPI Interface Data	
12	B0	I	Blue Data Bit 0	
13	B1	I	Blue Data Bit 1	
14	B2	I	Blue Data Bit 2	
15	B3	I	Blue Data Bit 3	
16	B4	I	Blue Data Bit 4	
17	B5	I	Blue Data Bit 5	
18	B6	I	Blue Data Bit 6	
19	B7	I	Blue Data Bit 7	
20	G0	I	Green Data Bit 0	
21	G1	I	Green Data Bit 1	
22	G2	I	Green Data Bit 2	
23	G3	I	Green Data Bit 3	
24	G4	I	Green Data Bit 4	
25	G5	I	Green Data Bit 5	
26	G6	I	Green Data Bit 6	
27	G7	I	Green Data Bit 7	
28	R0	I	Red Data Bit 0	
29	R1	I	Red Data Bit 1	
30	R2	I	Red Data Bit 2	
31	R3	I	Red Data Bit 3	
32	R4	I	Red Data Bit 4	
33	R5	I	Red Data Bit 5	

34	R6	I	Red Data Bit 6	
35	R7	I	Red Data Bit 7	
36	HSYNC	I	Horizontal Sync Input	
37	VSYNC	I	Vertical Sync Input	
38	DCLK	I	Dot Data Clock	
39	AVDD	I	Analog Power	
40	AVDD	I	Analog Power	
41	VDD	I	Digital Power	
42	VDD	I	Digital Power	
43	NC	I	Not Connected	
44	NC	-	Not Connected	
45	VGL	I	Gate Off Power	
46	NC	-	Not Connected	
47	VGH	I	Gate On Power	
48	NC	-	Not Connected	
49	NC	-	Not Connected	
50	NC	-	Not Connected	
51	VCOM	I	Driving Input	VcomH / VcomL
52	ENB	I	Data Enable Input	VDD / GND
53	GND	I	Ground	
54	GND	I	Ground	

I: Input pin; O: Output pin

Note 1. The polarity of VCOM should be generated from POL through driving circuit. The H/L voltage level of POL is VDD/GND. Hence, it cannot be used as Vcom signal directly. The phase shift from POL to Vcom can be set as either 0° or 180° by 3-wire SPI interface.

Note 2. For digital RGB input data format, both SYNC mode and DE+SYNC mode are supported. If ENB signal is fixed low, SYNC mode is used. Otherwise, DE+SYNC mode is used.

Note 3. SPENA、SPCLK are usually pulled high.

2. Absolute Maximum Ratings

Items	Symbol	Values		Unit	Condition
		Min.	Typ.		
Power Voltage	AVDD	-0.3	7.0	V	AVSS=0
	VDD	-0.3	7.0	V	GND=0
	VGH	-0.3	32.0	V	GND=0
	VGL	-22.0	+0.3	V	GND=0
	VGH-VGL	-0.3	+45	V	GND=0
Input Signal Voltage	V _i	-0.3	AVDD+0.3	V	
	V _I	-0.3	VDD+0.3	V	
LED Reverse Voltage	V _r	-	3.6	V	One LED
LED Forward Current	I _f	-	28	mA	One LED, Note 4
Storage Temperature	T _{ST}	-10	70	°C	Note 2
Operating Temperature (Ta)	T _{OP}	-0	60	°C	Note 2, Note 3

Note 1. If the operating condition exceeds the absolute maximum ratings, the TFT-LCD module may be damaged permanently. Also, if the module operated with the absolute maximum ratings for a long time, its reliability may drop.

Note 2. Temp. ≤60°C, 90% RH MAX

Temp. >60°C, Absolute humidity shall be less than 90% RH at 60°C

Note 3. The LCD module operating temperature, excluding touch panel, is from -10 to 70°C

Note 4. If LED current exceeds the limit curve, the lifetime will drop dramatically.

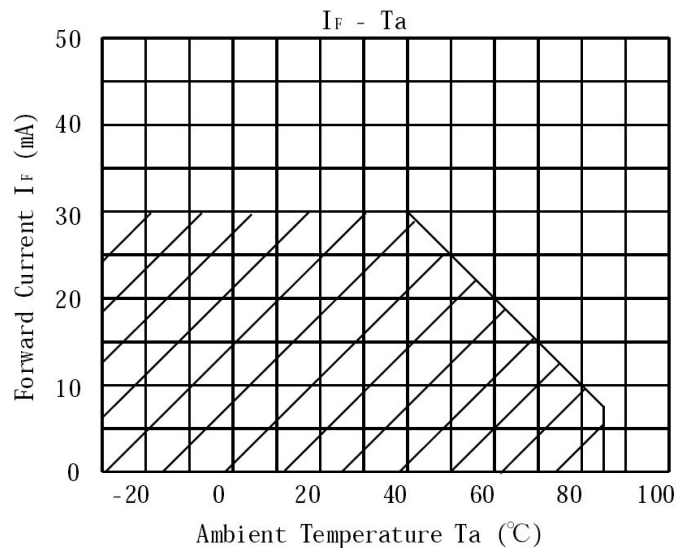

3. Electrical Characteristics

The following items are measured under stable condition and suggested application circuit.

a. TFT- LCD Panel (GND=0V)

Parameter	Symbol	Min	Typ	Max	Unit	Notes
Digital Power Supply	VDD	3.0	3.3	3.6	V	
Analog Power Supply	AVDD	4.9	5.0	5.1	V	
Gate On Voltage	V _{GH}	14	16	18	V	
Gate Off Voltage	V _{GL}	-11	-10	-8	V	
VCOM AC Amplitude	V _{COMAC}	4.8	5.0	5.3	V	Note 1
VCOM DC Voltage	V _{COMDC}	1.90	1.98	2.06	V	Note 2
Frame Frequency	f _{Frame}	55	60	65	Hz	
Dot Data Clock	DCLK	-	6.4	-	MHz	

Note 1. Vcom AC=VCOMH - VCOML: Adjust the color with gamma data.

Note 2. Vcom DC=1.98+0.025*(26-(V_{GH}-V_{GL}))

VCOM

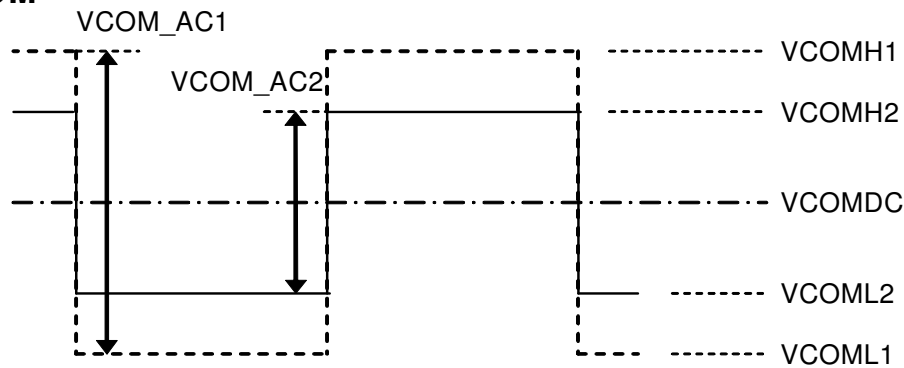

Note 3. Panel surface temperature should be kept less than content of section 3.2. "Absolute maximum ratings"

b. Backlight Driving Conditions

Parameter	Symbol	Min.	Typ.	Max.	Unit	Remark
LED Current	I_L	---	20	28	mA	single serial
LED Voltage	V_L	---	19.2	21.6	V	single serial
LED Life Time	L_L	10,000	---	---	Hr	Note 2, 3

Note 1: LED backlight is six LEDs serial type.

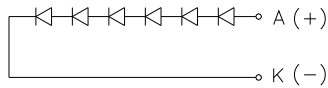

Note 2: The "LED Supply Voltage" is defined by the number of LED at $T_a=25^\circ\text{C}$, $I_f=20\text{mA}$. In the case of 6 pcs LED, $V_{LED}=3.2*6=19.2\text{V}$

Note 3: The "LED life time" is defined as the time for the module brightness to decrease to 50% of the initial value at $T_a=25^\circ\text{C}$, $I_f=20\text{mA}$

Note 4: The LED lifetime could be decreased if operating I_L is larger than 25mA

4. AC Timing

a. Timing Condition

Signal	Item	Symbol	Min	Typ	Max	Unit	
DCLK	Frequency	Dclk	6	6.4		MHz	
	High Time	Tch		78	80	ns	
	Low Time	Tcl		78	80	ns	
Data	Setup Time	Tds	12			ns	
	Hold Time	Tdh	12			ns	
HSYNC	Period	TH		408	432	DCLK	
	Pulse Width	Thp	5	30		DCLK	
	Back-Porch	Thb		38		DCLK	
	Display Period	Thd		320		DCLK	
	Front-Porch	Thf		20		DCLK	
VSYNC	Period	NTSC	Tv		262.5	TH	
		PAL			312.5		
	Pulse Width		Tvp	1	3	5	TH
	Back-Porch	NTSC	Tvb		15	TH	
		PAL			26		
	Display Period		Tvd		240		TH
	Front-Porch	NTSC	Tvf		4.5	TH	
		PAL			46.5		
VSYNC-ENB Time	NTSC	TVSE		18		TH	
	PAL	TVSE		26		TH	
HSYNC-ENB Time		THE		68		DCLK	
ENB Pulse Width		TEP		320		DCLK	

b. Timing Diagram

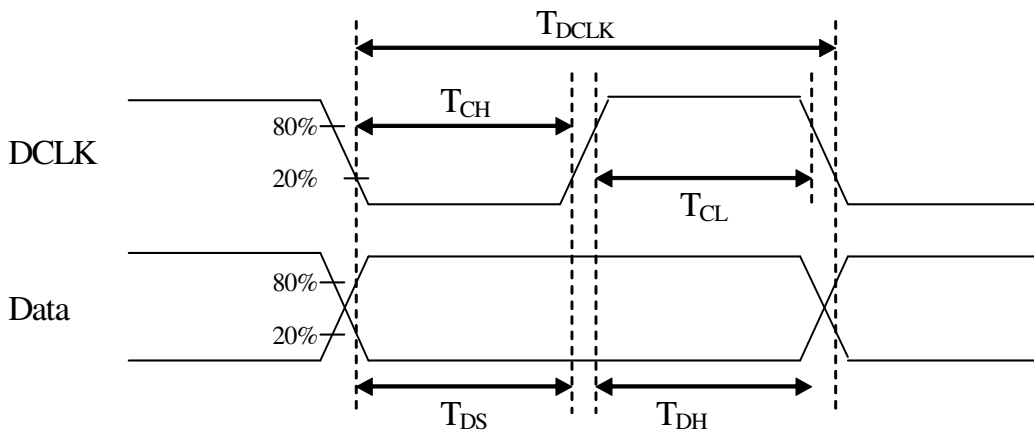
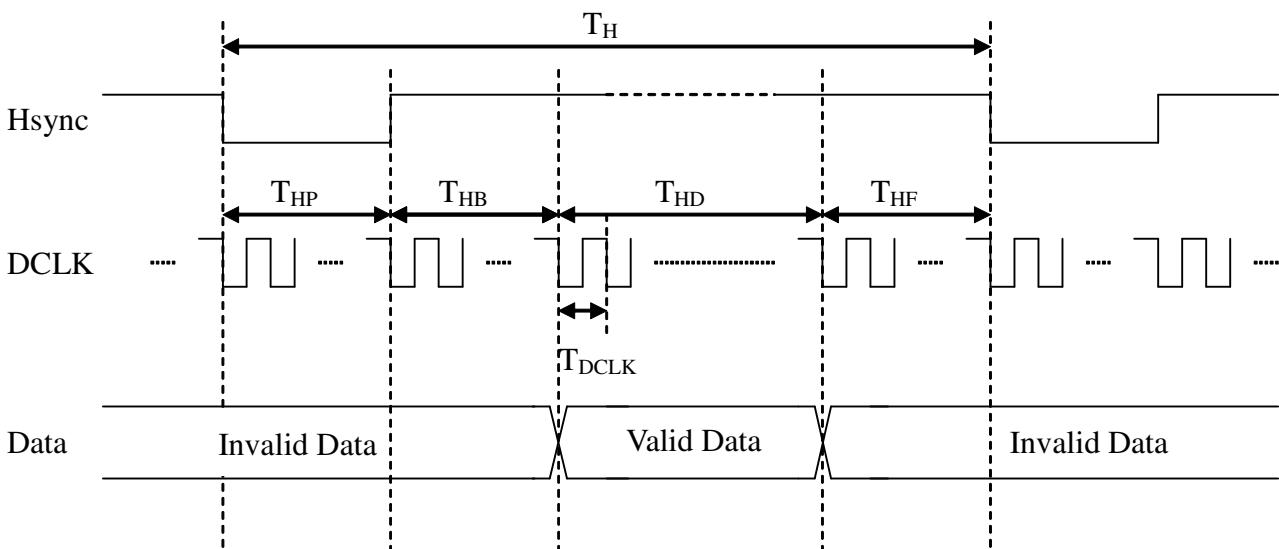
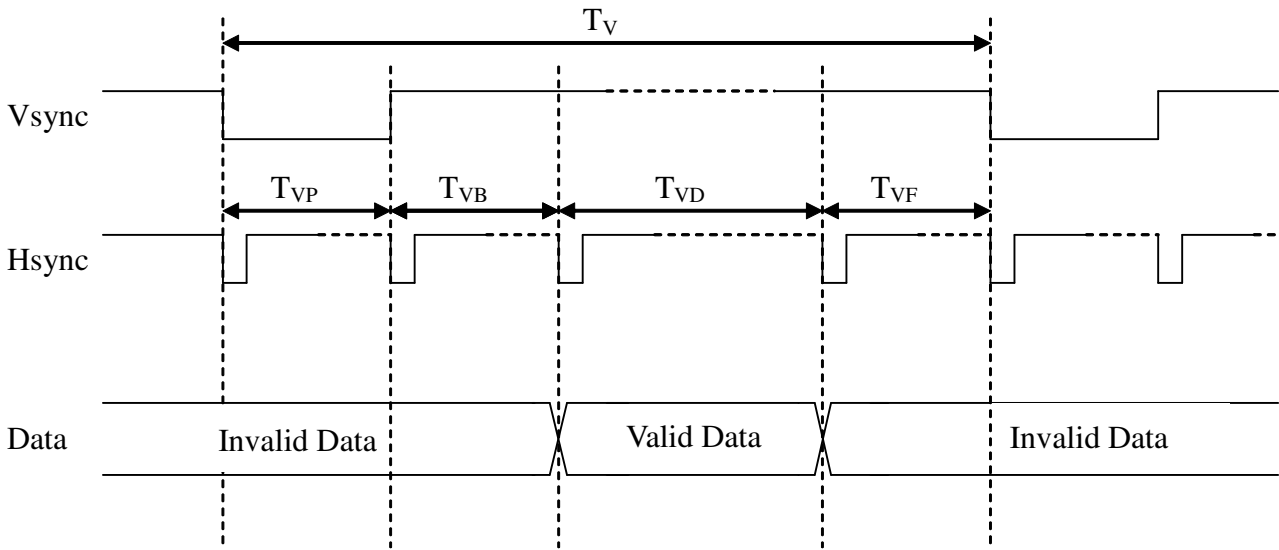

c. Description of serial control data

c-1. R0

Register	Address	D7	D6	D5	D4	D3	D2	D1	D0
R0	0h	Reserved(0)	Reserved(0)	Reserved(0)	STHP(00h)				

STHP [4:0]: adjust start pulse position by pixel

STHP [4:0]	STH position adjust by pixel
10h	-16
18h	-8
1Fh	-1
00h	0
08h	+8
0Fh	+15

c-2. R1

Register	Address	D7	D6	D5	D4	D3	D2	D1	D0
R1	1h	STVP (0h)			STVNT (00)		STVPAL (00)		

STVP [3:0]: adjust first line position by line

STVP [3:0]	STV position adjust by line
8h	-8
Ch	-4
Fh	-1
0h	0
4h	+4
7h	+7

STVNT[1:0]: Adjust the relationship of first line of active video in Odd/Even Field in NTSC mode.

STVNT [1:0]	Function description
00	The first line of active video in Even Field = The first line of active video in Odd Field
01	The first line of active video in Even Field = The first line of active video in Odd Field + 1
10	No Use
11	The first line of active video in Even Field = The first line of active video in Odd Field – 1

STVPAL[1:0]: Adjust the relationship of first line of active video in Odd/Even Field in PAL mode.

STVPAL [1:0]	Function description
00	The first line of active video in Even Field = The first line of active video in Odd Field
01	The first line of active video in Even Field = The first line of active video in Odd Field + 1
10	No Use
11	The first line of active video in Even Field = The first line of active video in Odd Field – 1

c-3. R2

Register	Address	D7	D6	D5	D4	D3	D2	D1	D0
R2	2h	Reserved(1)	RGBVPOL(0)	Reserved(1)	Reserved(0)	Reserved(1)	HS_POL(0)	NPC_IN(1)	NPC_SET(0)

RGBVPOL: VS polarity setting for Serial/Parallel RGB

RGBVPOL = "L", negative polarity.

RGBVPOL = "H", positive polarity

HS_POL: HS polarity setting for CCIR601 and Serial/Parallel RGB.

HS_POL=L, negative polarity.

HS_POL=H, positive polarity.

NPC_IN: Define the NTSC/PAL mode by SPI.

NPC_IN=L, PAL.

NPC_IN=H, NTSC.

NPC_SET: Set the NTSC/PAL auto detection or define by NPC_IN.

NPC_SET=L, auto detection.

NPC_SET=H, define by NPC_IN.

c-4. R3

Register	Address	D7	D6	D5	D4	D3	D2	D1	D0
R3	3h	Reserved(1)	Reserved(0)	Reserved(01)	Reserved(0)	POL_OUT(0)	DE_POL(0)	DE_SEL(0)	

POL_OUT: POL phase select

POL_OUT=L, POL and VCOM are in phase.

POL_OUT=H, POL and VCOM are reverse.



DE_POL: DE signal polarity setting.

When DE_SEL=L:

DE_POL =L, positive polarity.

DE_POL =H, negative polarity.

When DE_SEL=H:

DE_POL =L, negative polarity.

DE_POL =H, positive polarity.

DE_SEL: DE mode select.

DE_SEL=L, DE signal with HS and VS signal

DE_SEL=H, DE signal only

F. Optical specifications (Note 1, 2)

Item	Symbol	Condition	Min.	Typ.	Max.	Unit	Remark
Response Time							
Rise	Tr	$\theta = 0^\circ$	-	10	20	ms	Note 3, 4
Fall	Tf		-	15	25	ms	
Contrast ratio	CR	At optimized viewing angle	150	300	-		Note 5, 6
Viewing Angle							
Top		CR ≥ 10	35	50	-	deg.	Note 7, 8
Bottom			40	55	-		
Left			45	60	-		
Right			45	60	-		
Brightness	Y _L	$\theta = 0^\circ$	350	400	-	cd/m ²	
White Chromaticity	X	$\theta = 0^\circ$	0.26	0.31	0.36		
	y	$\theta = 0^\circ$	0.28	0.33	0.38		

Note 1: Measurement should be performed in the dark room, optical ambient temperature =25°C, and backlight current I_L=20 mA

Note 2: To be measured on the center area of panel with a field angle of 1° by Topcon luminance meter BM-7, after 10 minutes operation.

Note 3: Definition of response time:

The output signals of photo detector are measured when the input signals are changed from “black” to “white”(falling time) and from “white” to “black”(rising time), respectively.

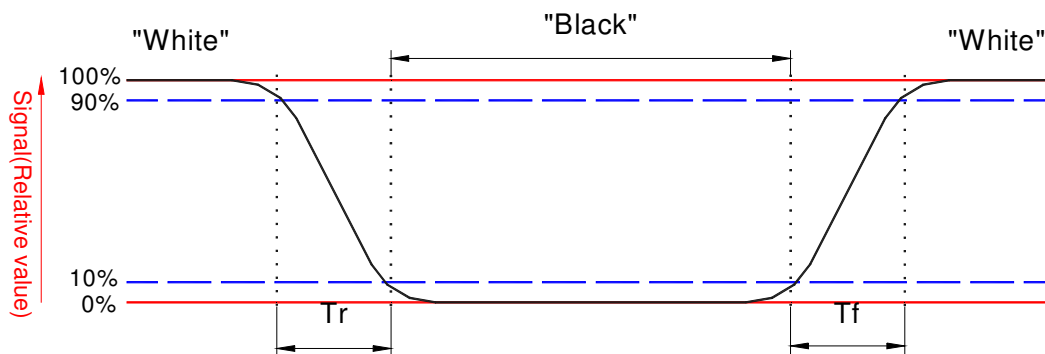

Note 4. From liquid crystal characteristics, response time will become slower and the color of panel will become darker when ambient temperature is below 25°C.

Note 5. Contrast ratio is calculated with the following formula.

$$\text{Contrastratio} = \frac{\text{Photo detector output when LCD is at "White" state}}{\text{Photo detector output when LCD is at "Black" state}}$$

Note 6. White $V_i = V_{i50} \mu 1.5V$

Black $V_i = V_{i50} \pm 2.0V$

“±” means that the analog input signal swings in phase with COM signal.

“μ” means that the analog input signal swings out of phase with COM signal.

V_{i50} :The analog input voltage when transmission is 50%

The 100% transmission is defined as the transmission of LCD panel when all the input terminals of module are electrically opened.

Note 7. Definition of viewing angle: refer to figure as below.

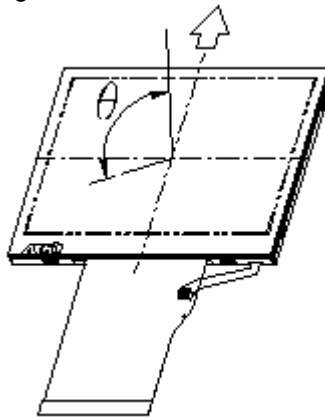

Note 8. The viewing angles are measured at the center area of the panel when all the input terminals of LCD panel are electrically opened.

G. Reliability Test Items

No.	Test items	Conditions		Remark
1	High Temperature Storage	Ta= 70°C	240Hrs	
2	Low Temperature Storage	Ta= -10°C	240Hrs	
3	High Temperature Operation	Ta= 60°C	240Hrs	
4	Low Temperature Operation	Ta= 0°C	240Hrs	
5	High Temperature & High Humidity	Ta= 60°C. 90% RH	240Hrs	Operation
6	Heat Shock	-25°C~70°C, 50 cycle, 2Hrs/cycle		Non-operation
7	Electrostatic Discharge	±200V,200pF(0Ω), once for each terminal		Non-operation
8	Vibration (With Carton)	Random vibration: 0.015G ² /Hz from 5~200Hz -6dB/Octave from 200~500Hz		IEC 68-34
9	Drop (With Carton)	Height: 60cm 1 corner, 3 edges, 6 surfaces		

Note : Ta: Ambient temperature.

Note 2 : All tests are based on typical electrical settings and default register settings.

H. Packing Form

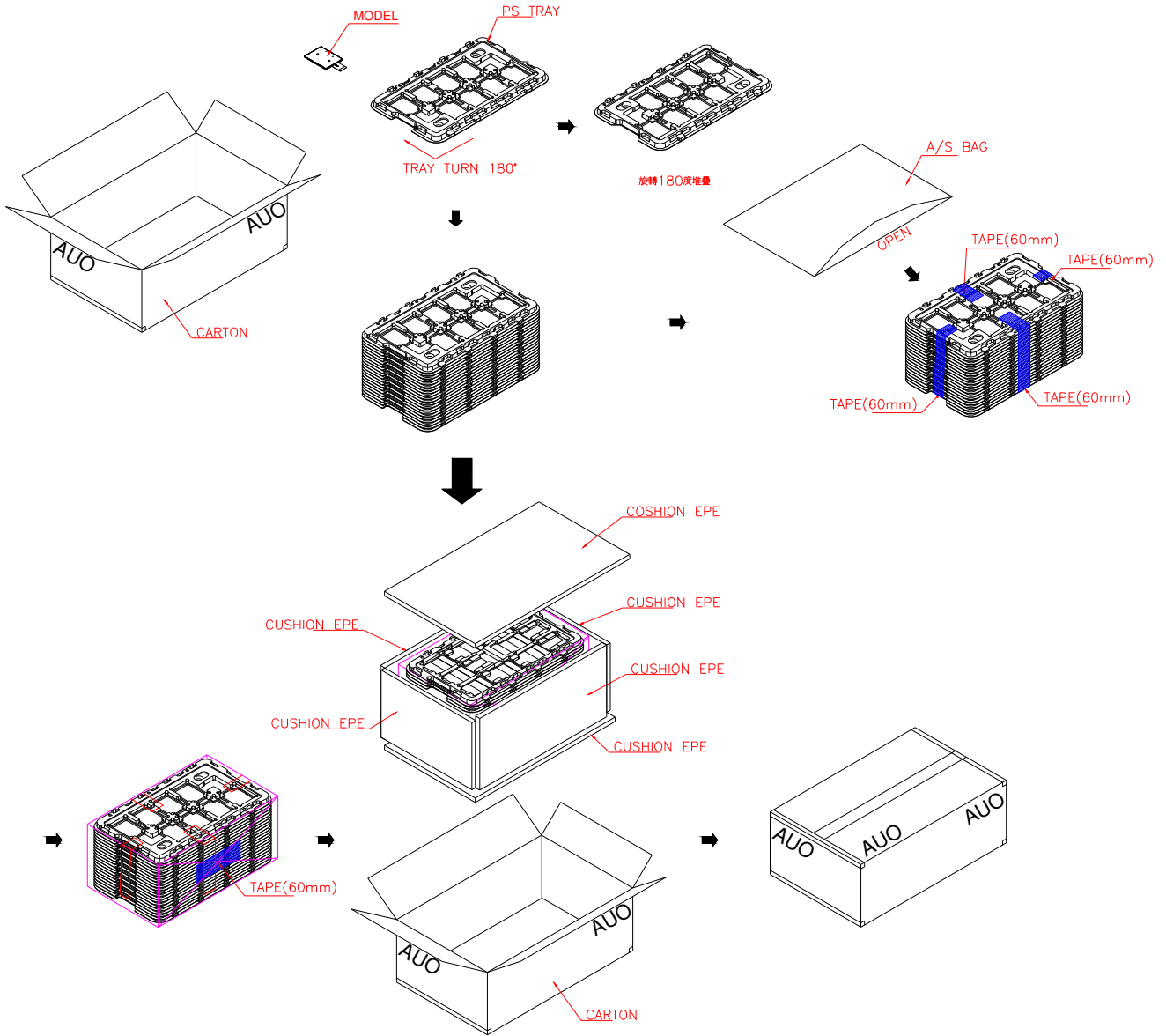

MAX. CAPACITY: 160 MODULES
MAX. WEIGHT: 12Kg
MEAS. 520mm*340mm*250mm

I. Application Note

1. Power on/off sequence

The LCD panel adopts high voltage driver ICs, so it could be permanently damaged if a wrong power on/off sequence is used. When powering on the LCD, VDD should go up firstly, and then turn on VGL and AVDD, and finally VGH. Turn off the LCD panel with reversed order or shut off all the power supplies simultaneously.

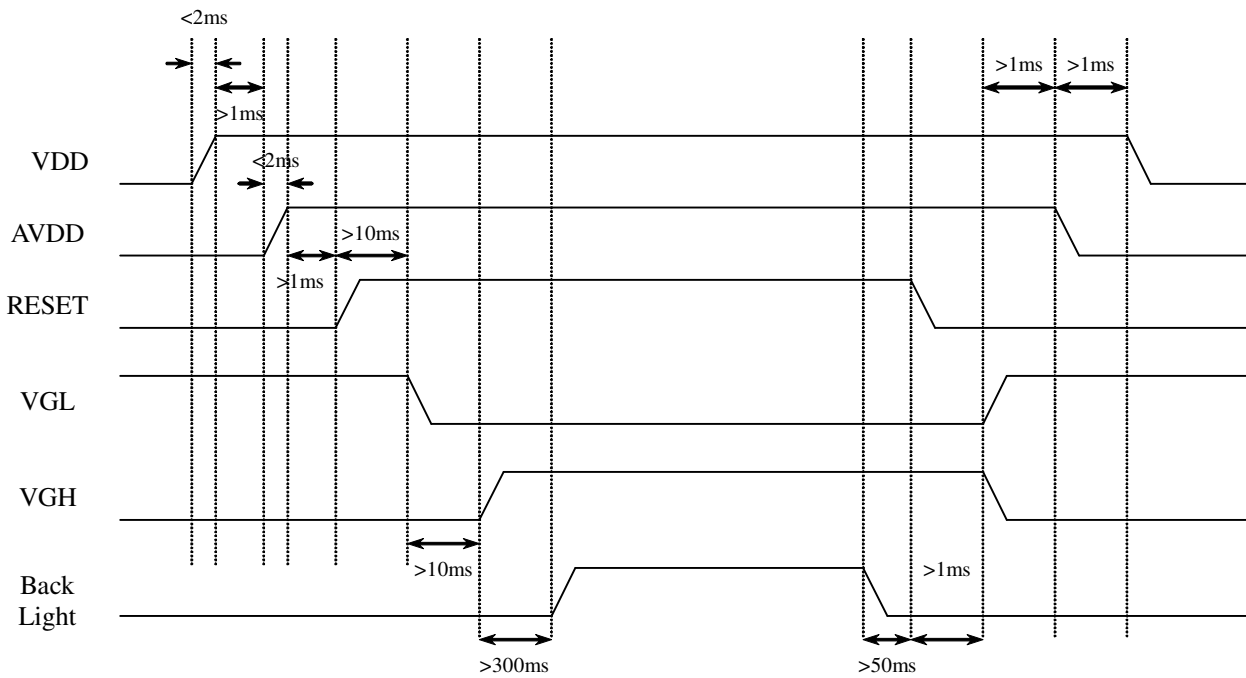

2. Application Notes – Vcom driving circuit

POL which is a digital output signal from LCM is used to generate Vcom signal. According to register R3, when POL_OUT is 'L', POL and Vcom are in phase. Otherwise, POL and Vcom are reverse. Below application circuits are for POL_OUT='L' and POL_OUT='H', respectively. In the typical condition, Vcom AC is equal to 5V.

a. POL and Vcom are in phase (POL_OUT='L')

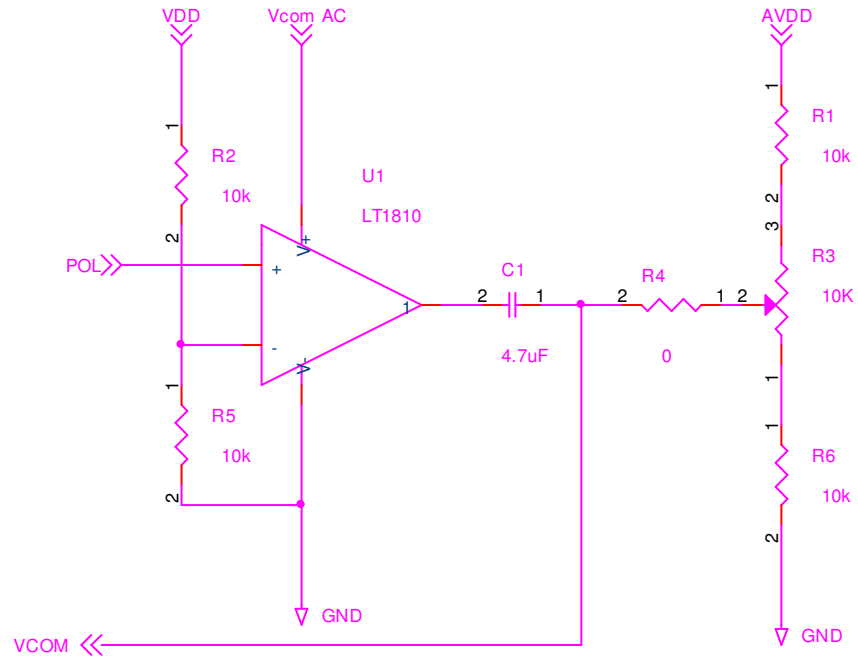

<Note> : The resistors R1, R3 and R6 are used to optimizing flicker by adjusting VcomDC value which equals to

$$\frac{1}{2}(VcomH + VcomL).$$

b. POL and Vcom are reverse

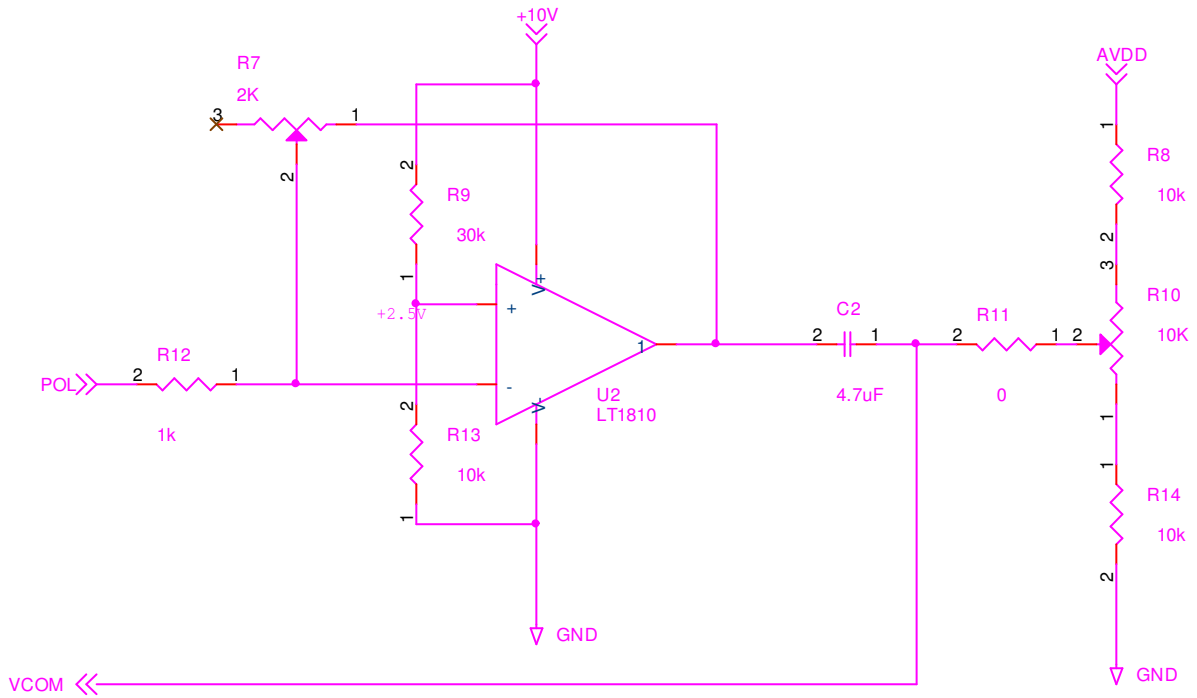

Based on above circuit Vcom AC are following the equations as below

$$Vcom AC = VDD * \frac{R_7}{R_{12}}$$

<Note> : The resistors R8, R10 and R14 are used to optimizing flicker by adjusting VcomDC value which equals

$$\text{to } \frac{1}{2}(VcomH + VcomL).$$